

INNO[®] **MOBILIS**

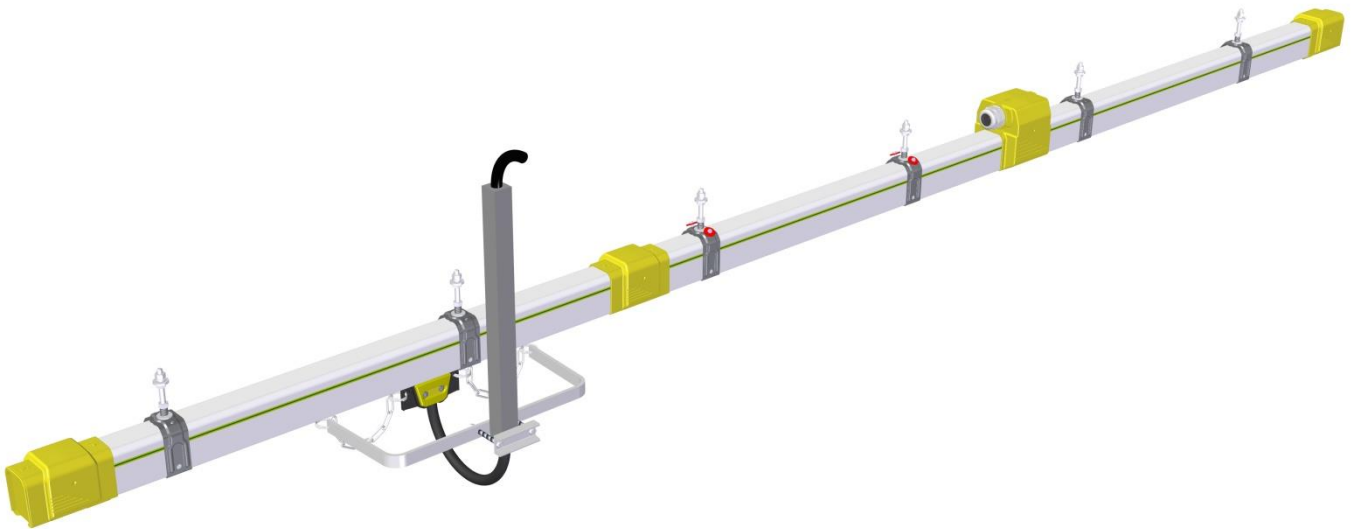

Electrical supply rail **40A - 60A**



Contents

Presentation	3
Technical data.....	5
1-Standard straight element	10
2-Ventilation element.....	12
3-Clipped junction connection	14
4-Feeding connection	16
5-Covering flange.....	18
6-End-cap.....	20
7-Sliding hanger	22
8-Fixed hanger	24
9-End-line feed box.....	26
10-M25-M32 in-line feed box.....	29
11-M40 in-line feed box	32
12-Rigid trolleys.....	35
13-Carrier.....	38
14-Carrier with box.....	40
15-Switching finger.....	42
16-Bracket.....	43
17-Cleaning trolley.....	45
18-Replacement parts	47
GUARANTEE	48



Presentation

The electrical supply rail Mobilis Inno meets the requirements of the most demanding manufacturers, installers, and end-users of mobile equipment: **safety, compact, fast assembling, operation reliability, and easy maintenance of this electrical supply rail for travelling cranes and other mobile equipment requiring mobile power socket.**

EXCELLENT SAFETY AND OPERATOR PROTECTION:

The closed profile of the mounted line with the full set of accessories has a protection level of IP23, which means that the equipment is protected so that people cannot access the dangerous sections, even under the rain. All the accessories ensure the IP23 level.

OTHER KEY POINTS

Quick installation:

Multiple pole lines with 4 pre-mounted conductors and many accessories to clip-on (no tools required)

Reduced voltage drop at connections:

The very large exchange surface and the always optimum contact pressure allow reducing and controlling voltage drop

Operating reliability:

The current collectors, tested against requirements stricter than the standards, provide high lifetime performance allowing reduced maintenance of facilities

Compact and ergonomic:

Optimized dimensions allow easier installation in case of low installation space and contribute to a lighter product

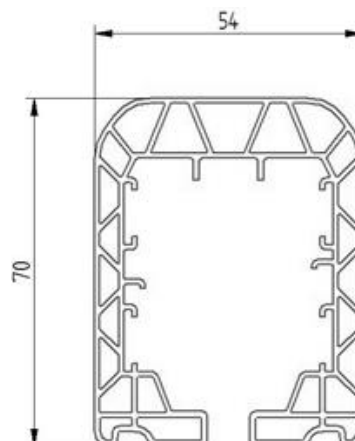

DETAILS OF MOBILIS INNO PROFILE

- › Number of poles : 4
- › Intensity: 40A, 60A
- › Maximum operating voltage: 690 V

STANDARDS

- › Protection level IP23 according to EN60529
- › Meets the requirements of Standards EN61439-1, EN61439-6, EN60204-32 and EN60529 (IP23)

SPECIALS ACCESSORIES AVAILABLE

- › Ventilation element
 - › Switching finger
-

BENEFITS :

- › New range inspired from MOBILIS ELITE:
 - Safety
 - High rank of design and performance
 - Easier to install, to use and to maintain
 - Design and brand color respected (clear grey profile, yellow accessories)
 - Economically optimized
- › Self-supporting PVC Profile with optimized cellular structures, closed, design and compact, for a minimal weight (Mobilis was the first to introduce the cellular PVC profiles on the market. The INNO profile is 35% more compact than the ELITE)
- › Floating conductors fitted inside the profile to take into account the expansion differences of line's synthetic material.
- › Optimized conductors copper section regarding the couple « intensity/length »
- › Easy and quick mounting by clip on of the rails lighter in the self-alignment sliding hangers and mountable accessories without tools
- › Innovative junction connection, quick mounting without tool, dismountable and reusable
- › No need of conductors preparation
- › Short conductors extremities without laterally overshoot regarding the PVC profile, reducing the risk of deformation and damage during transportation and installation
- › Reinforced safety :double wall profile, maximal rigidity against access to dangerous inner sections under tension, wide insulating distances, adapted for use under rain, earth conductor marked on the total length, poles labels for the wiring
- › New concept for feed boxes shells with clip closing that can be placed indifferently in line or at the end of the line
- › Two end-line feed box executions
 - one with cable gland on the bracket for a comfortable wiring with held cable
 - one with cable gland on the shell for space saving at the end of the line
- › Insulated junction with quick mounting without tools covering flange
- › Modular product with standard length of 1, 2, 3 and 4m easy interchangeable for evolving lines that can easy be extended or shorted.
- › Line length until 250m without expansion joint.
- › Optimized carrier intensity 30A regarding the current need for cranes applications
- › Reduced package quantity for lower environmental impact
- › Easier maintenance thanks to the modularity, the reusable connections and thanks the easy sliding ability of line elements in the sliding hangers
- › Large series manufacturing, short time delivery available product
- › Line calculation software

Technical data

1. USE

The electrical supply rails with mobile socket Mobilis INNO are generally used for the electrification of Systems with straight trajectory like travelling cranes, cranes and hoists, narrow-aisle stores, work station equipment (tasksaver systems), elements of electric hoisting equipment and other diverse applications, inside and outside.

2. GENERAL TECHNICAL DATA:

Rated operational intensity:

The MOBILIS INNO lines are available in rated intensities 40A and 60A.

The real current capacity depends on the operating factors and the ambient temperature.

Number of poles:

4 poles

The ground conductor (PE) is marked on the line by a green-yellow band.

Rated operational voltage:

690V, 50Hz, 60Hz, or DC

Temperature of use:

-30°C to +55°C

Maximal trolley speed:

60m/min

3. ENVIRONMENT:

Category 3 of ISO 2081 (outside mild), inside, outside use under rain or dust.

The Mobilis INNO system is designed to work with the opening downwards. Validate the ability of the product to operate in an unfavorable environment (ex: humid air flow, steam, frost, etc.). A version with 600h resistance under saline mist is available, on request.

In case of harsh conditions of high humidity type, dust, frost, snow, ice, temperatures > 55 ° C or others, prefer the Mobilis Elite range with the respect of our recommendations for these specific environments.

4. APPLICABLE STANDARDS:

The Mobilis INNO range has been designed to meet Standards EN61439-1, EN61439-6 et EN60204-32. It bears the CC marking.

5. PROTECTION INDEX:

A mounted line with the full set of accessories has a protection level of IP23 according to EN60529.

Caution: If one accessory is removed, the level of protection is eliminated and the conformity is lost.

IP2X means that the equipment is protected so that people cannot access the dangerous sections, i.e. it is impossible to introduce a standard test finger of $\text{Ø}12$ mm with an effort of 10 N. The equipment is also protected against solid foreign bodies, i.e. it is not possible to introduce a metal sphere of $\text{Ø}12.5$ mm with an effort of 30 N.

IPX3 means that the equipment is protected against rainwater falling at a maximum angle of 60° in relation to the vertical plane.

The Mobilis INNO range is designed for both indoor and outdoor uses.

If a Mobilis INNO line is used in an area open to the public, additional safety measures should be installed (protection level IP4X required according to EN60204-32).

6. INSULATION DISTANCES:

Insulation distance between conductors or between conductors and accessible parts:

- Distance in the air: 10 mm min, adapted to overvoltage category No. III ie 6kV according to EN61439-1.
- Creepage distance: 30 mm min. (according to EN60204-32)

7. FLAME RESISTANCE:

All materials used to build Mobilis INNO lines are self-extinguishing; they pass successfully glowing/hot line tests under 960°C for elements in contact with live parts and V-0 according to UL-94.

8. SAFETY PINS

Line: identification of ground conductor: The ground conductor (PE) is marked on the whole line's length with a green-yellow band. The poles are marked on the connecting points on the line and on the collecting trolleys.

Trolley: with the safety pin system, it is not possible to insert a trolley into the line incorrectly, leading to a phase-earth connection or a reversal of the direction of the poles.

9. SPACE REQUIREMENTS:

In addition to the space required for the various components (see in this section), consider enough space for mounting/dismounting of electrical wiring.

For ergonomic reasons, we recommend a free access next to the rail of 100mm or 127mm from the axis of the element.

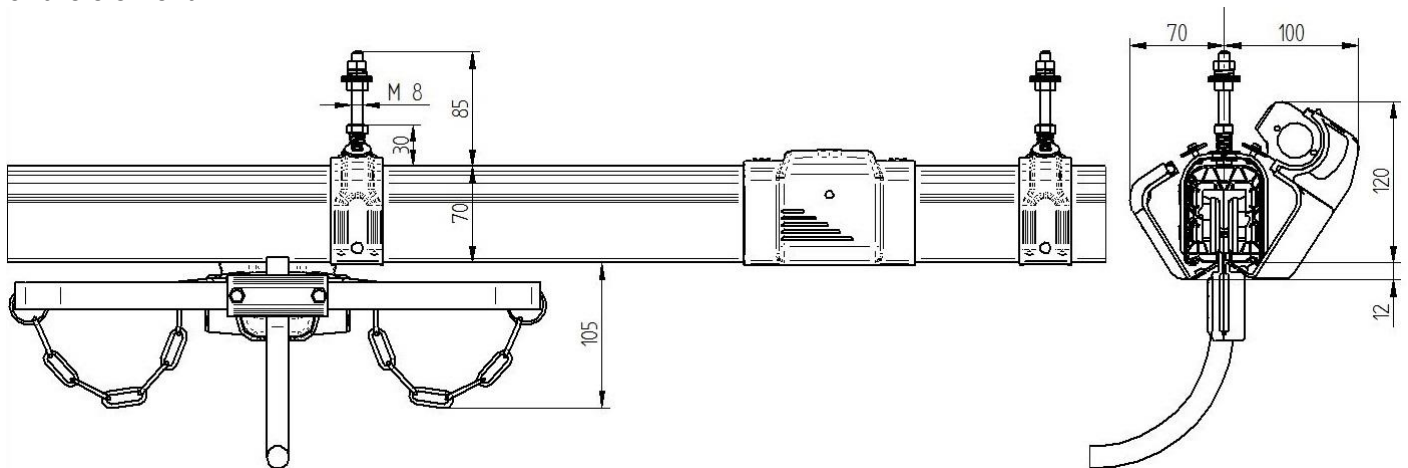

10. OPERATING LIFE - ENDURANCE

The lines and accessories are built to withstand several years of use in a normal industrial environment. The current collectors are designed to run at least 2000 kilometers (see the Maintenance section §15 for recommended service schedule).

11. RESISTANCE, REACTANCE, AND IMPEDANCE UNDER NORMAL CONDITION

Impulse running:

When the inrush current is of short duration followed by long rest periods, the figures in the table below can be used.

The value of the resistance R, reactance X and impedance Z at 50 Hz at ambient temperatures of 20°C and 35°C (CEI61439-6) and 40°C (EN60204-32) for short period current: the figures in the table are given in mΩ/m.

Intensity	40A	60A
R ₂₀ or R at 20°C	1,83	1,23
R (at 35°C)	1,94	1,31
R at 40°C	1,98	1,33
X	0,25	0,17
Z ₂₀ or Z at 20°C	1,85	1,24
Z (at 35°C)	1,96	1,32
Z at 40°C	1,99	1,34

Intensive running:

See the maximum intensity for a 100% duty cycle in the next paragraph.

12. INTENSITY ACCORDING TO DUTY CYCLE:

Ambient temperature	Duty cycle	Intensity	
		40A	60A
35°C	80%	63A	87A
40°C	80%	59A	76A
55°C	80%	46A	51A
35°C	100%	59A	83A
40°C	100%	56A	71A
55°C	100%	44A	47A

13. PROTECTION AGAINST SHORT-CIRCUITS:

For intensities 40A and 60A, $I_{cw} < 10kA$.

14. LIGNE CALCULATION

This paragraph gives a diagram to calculate the intensity required for your application: select your line's length and check that for each rating, the rated current required by your motor is supported by the line.

VOLTAGE DROP ACCORDING TO THE POSITION OF FEED BOXES

A judicious arrangement of the supply points makes it possible to reduce the voltage drop.

Positioning several power points on the line limits the voltage drop. (Caution: Make sure that the wiring does not interfere with expansion of the line, for example by using flexible cables or with a sufficient loop if rigid cables are used).

If L represents the length of the line, Lt represents the maximum length of the section to be considered for the determination of the voltage drop.

Example: an in-line feed box halves the length L_t of the section to be considered on the diagram. In this case, a 60A line of 160m with a feed box in the middle accepts a current of 60A with a voltage drop of less than 3%.

One feed box at the end of the line

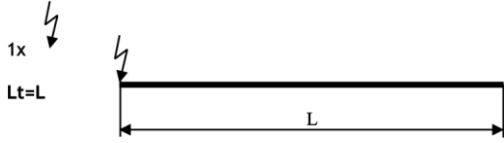

One feed box on line

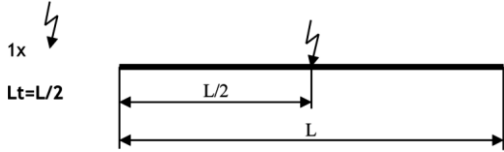

Two feed boxes

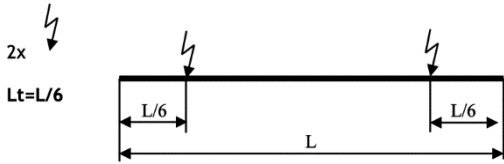

Three feed boxes

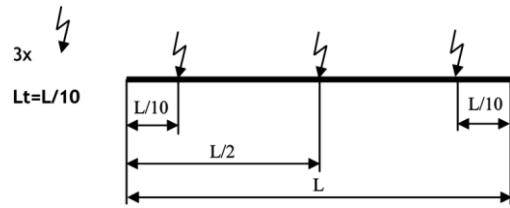

Four feed boxes

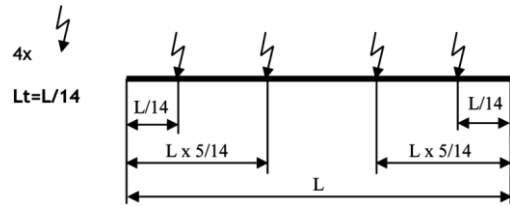

Diagram

INNO line Voltage Drop at 40°C for 400V AC 50Hz

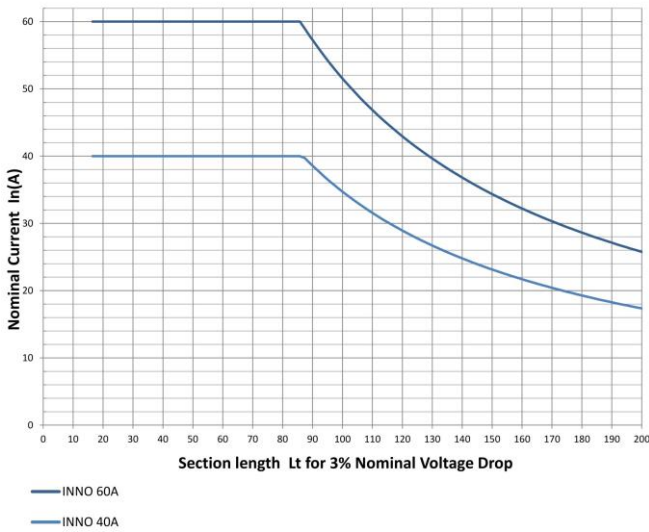

INNO line Motor Start Voltage Drop at 40°C for 400V AC 50Hz

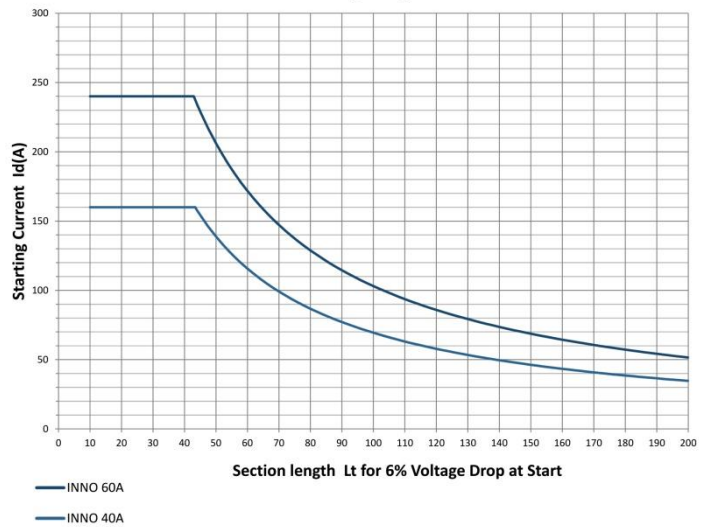

15. MAINTENANCE:

1) General points

Any intervention must be carried out **offline only**.

Maintenance primarily concerns the conductors and the trolleys.

Any damage to the conductors will reduce the operating life of the brushes.

This damage may take different forms:

- Oxidation due to a chemical environment
- Abrasive dust
- Damage due to electrical arcs in the case of a faulty contact following oxidation, heavy soiling or use of worn brushes.

Regular inspection is required to check the wear of the brushes, casters of wheels and the quality of the conductive tracks according to the rate of use, the distance covered, and the chemical environment.

Inspection is required when the distance covered reaches 2,000 km or after one year of use at the most.

2) Monitoring the conductors

The conductors normally become covered with a protective black sheen with the repeated passage of the collector trolleys. Check the surface condition of the conductors at a junction point between two lines' elements. The surface should be smooth. If the conductors are rough to the touch, run the cleaning trolley. You will find them under the components section.

Caution: the cleaning trolley is not designed to run over long distances, its brushes wear down faster than the conventional brushes.

3) Brushes checking

Switch off the line, take out the collector.

The replacement of the brushes depends on the line's intensity, since the thicker the conductor is, the greater is the wear reserve.

4) Monitoring of trolleys

Replace MOBILIS INNO trolleys every 2,000 km approximately or in the event of excessive wear of the driving rings, chains, of the central section of the trolley casing, or of the casters.

Ensure the safety pins are present when mounting.

Remove the dust at trolley's sides to preserve the insulation performance.

Check particularly the following points:

- Absence of excessive play of caster axle
- Absence of excessive lateral play
- Absence of wear of guiding sides
- Free rotation of wheels

5) Maintenance elements

Refer to the section "Replacement parts" for the following items:

⇒ Replacement connections

⇒ Replacement brushes

⇒ Replacement cleaning brushes

1-Standard straight element

Modular straight element of predefined length with 4 integrated copper conductors

Advantages

- Ends ready to receive their connections.
- Compact and rigid.

Description

Modular element which ensures the transmission of the current and the guidance of the collector trolleys.

Green-yellow protective conductor identification strip over the entire length.

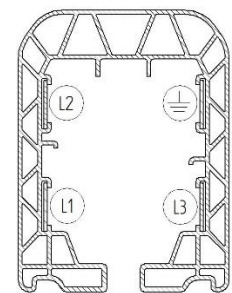
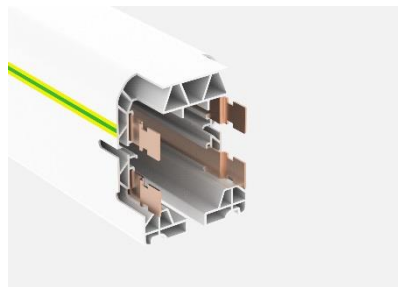
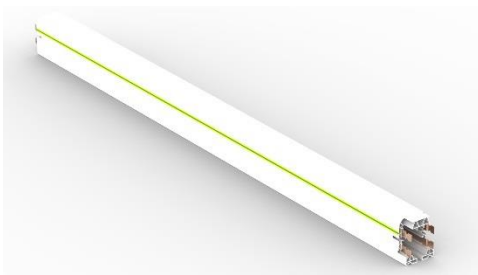

Product number and compatibilities

The standard straight elements are available with varying lengths of 4m, 3m, 2m, 1m and special length. The intensities indicated are valid for 50Hz, 60Hz and D.C.

Intensity	40A	60A
I _{Max} Current for 100% duty cycle 35°C / 40°C	62A/58A	78A/72A
Section L1, L2, L3, PE	copper 9,5mm ²	copper 14,4mm ²
Weight (kg/m)	1,3	1,5
Length 4m	MI4404	MI4604
Length 3m	MI4403	MI4603
Length 2m	MI4402	MI4602
Length 1m	MI4401	MI4601
Special length	MI4400	MI4600

Technical data

Standard straight element provided for clipper connection system (be careful they are not included with the straight element), quick to fit.

'Floating' conductors fitted to manage the differences in expansion with the PVC line. The protection conductor is identified by a green-yellow band over the entire length of the element.

Overall dimensions

L (mm) : 54

H (mm) : 70

Rated voltage

690V

Rated temperature

-30°C to +55°C

Material

Self-extinguishing and lead-free PVC color light grey, copper

Mounting

Installation rules

After installing the suspension parts, clip the straight elements one behind the other in the sliding suspensions, keeping a distance of 0.35m between the first suspension and the end of the first element. Connect the ends of the conductors by using the independent connections (reference: MI1000).

Mounting rules

1. Insert the lines in the sliding hangers, 2. Connect the lines

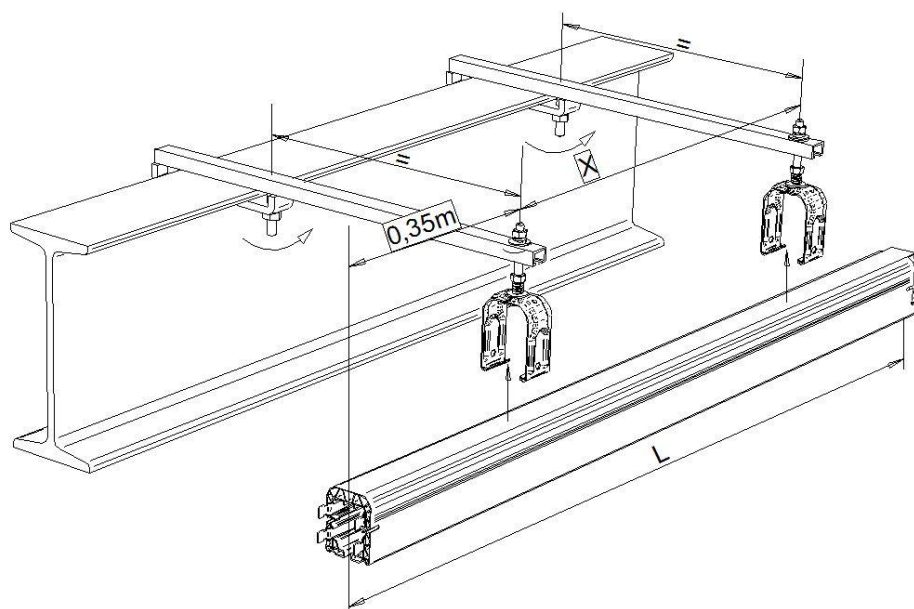

Mounting and dismounting required tools



2-Ventilation element

Limits condensation in a line with a warm section (interior) and a cold section (exterior) of a building.

Advantages

- Limits condensation
- Available in 2 lengths

Description

The purpose of the ventilation element is to limit condensation in a line with a warm section (inside the factory) and a cold section (outside the factory).
In case of high humidity (working process using water, presence of animals, etc.) prefer Mobilis Elite with the possibility of rubber gasket.

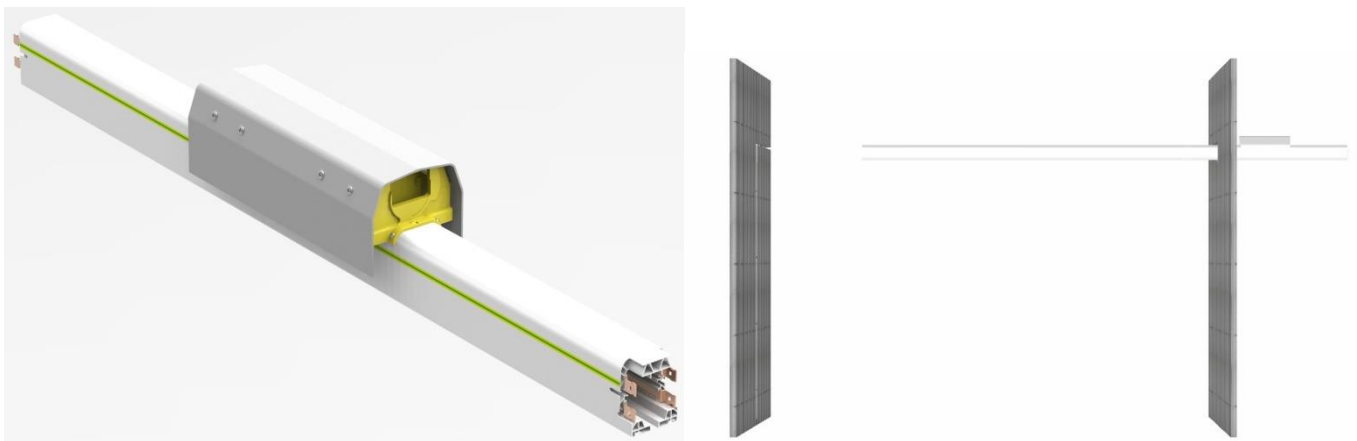

Product number and compatibilities

Intensity	Reference		Length A
	40A	60A	
Length 1m	MI5300	MI5301	350mm
Length 4m	MI5340	MI5341	1850mm

Technical data

Overall dimensions

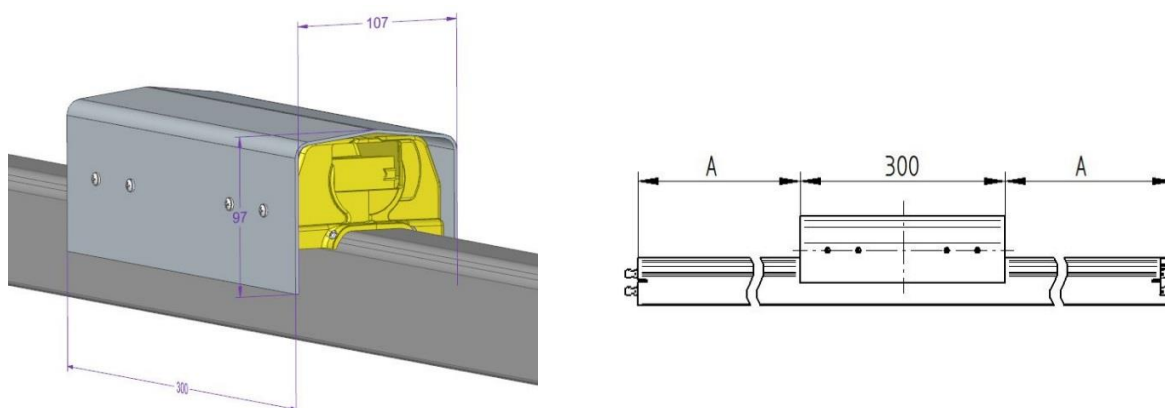

Mounting

Installation rules

The ventilation element is to be fitted like a standard element at the exit of the building (at the start of the cold area). The edge of the PVC cap must stand in the cold area at a distance of 200 to 500 mm from the warm area. Provide 2 sliding hangers, with a center axis distance of 500mm for a 1m element, and of 2m for a 4m element.

Mounting rules

Same as the right element

1. Insert the ventilation element into the suspensions, 2. Connect the ventilation.

Mounting and dismounting required tools



3-Clipped junction connection

Mechanical and electrical connection between the different straight elements of the line.

Avantages

- Quick assembly without tools
- Low voltage drop

Description

The junction connection, placed at the straight elements junctions, ensures the electrical and mechanical continuity of the conductors along the entire length of the line.

The rear face, opposite the spring, is provided to ensure the passage of the brushes of the collector carriage at the junction.

Same for the 2 intensities, it is removable and reusable.

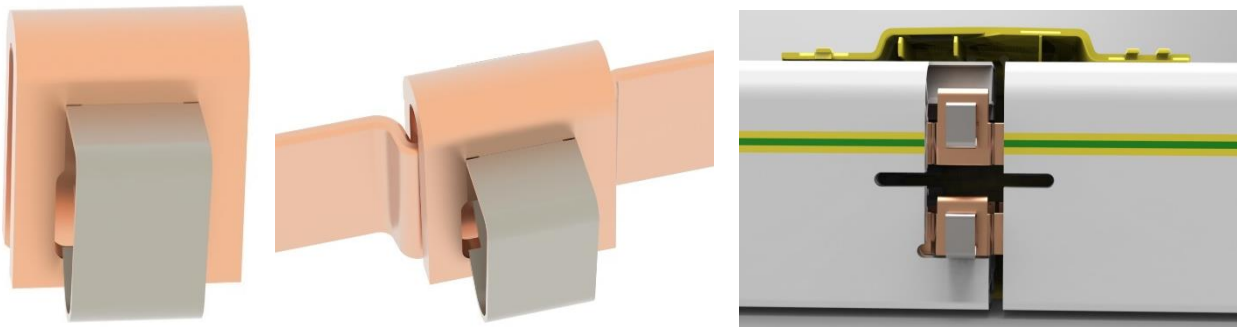

Product number and compatibilities

MI1000

Technical data

Material: Copper, Stainless steel.

Mounting

Installation rules

Place a connection for each conductor to be connected to the next straight element (except at the feeding point).

Mounting rules

Overlap the 2 ends of the same pole to be connected. The conductor with the tabs is placed on the outside of the PVC profile and the tabs are positioned in the notches of the other end of the conductor.

Place the connections of the bottom conductors first, then those of the upper conductors.

A "click" of security is heard when the connection is well placed.

Mounting drawing:

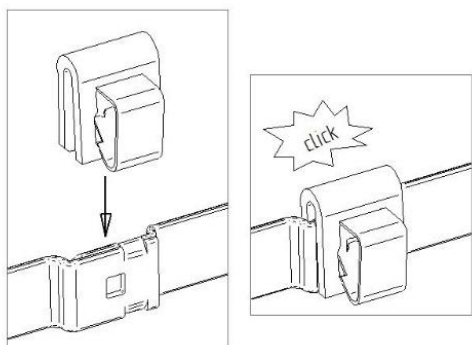

Dismounting required tools

Special Mobilis INNO, part number MI9003, supplied with the connections, facilitates assembly and disassembly

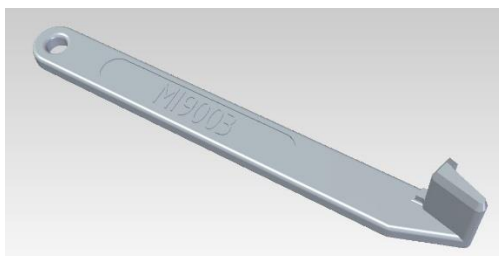

VIDEO : www.mobilis.help/innomov

4-Feeding connection

Electrical link between the network and the line in the feed-box.

Avantages

- Possibility to connect lugs Ø5mm
- Mounting in line or at the end of the line

Description

The feeding connections are used to connect the power cables with lugs to the Mobilis INNO lines. For an in-line feed box, they are installed instead of junction connections. They are included in the feed boxes.

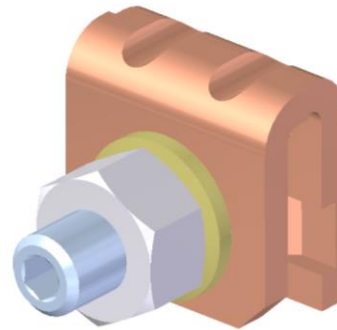
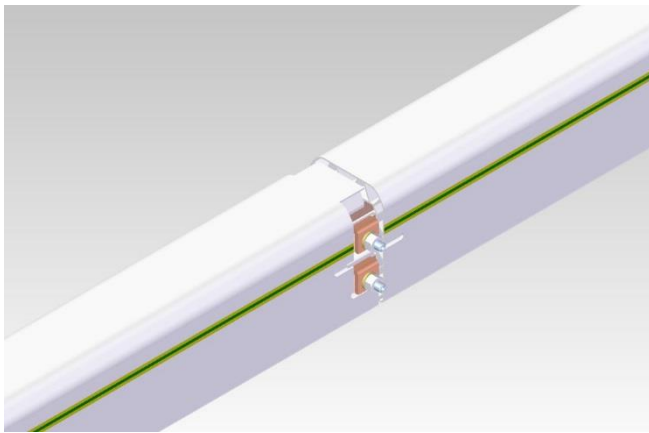

Product number and compatibilities

MI1010

Technical data

For terminals Ø5mm

Material: Copper

Mounting

Installation rules

On conductors that overlap with the tabs in the slots for an in-line feed box or on a conductor end for an end-line feed box, mount the connection's smooth side to the inner side of the PVC-profile. Make sure to maintain isolation distances in the air between the poles when wiring.

Mounting rules

Remove the nut and the washer.

In-line feed box: Overlap the conductors as for a junction connection. Loosen the screw and slide the jumper to the stop on the conductors. Tighten the screw to the hard point.

End-line feed box: Place the jumper with help of the conductor pins if necessary, tighten the screw to the hard point.

Place the terminal with its cable on the screw, place the contact washer and tighten the nut to the indicated torque.

See more details in chapter feed box.

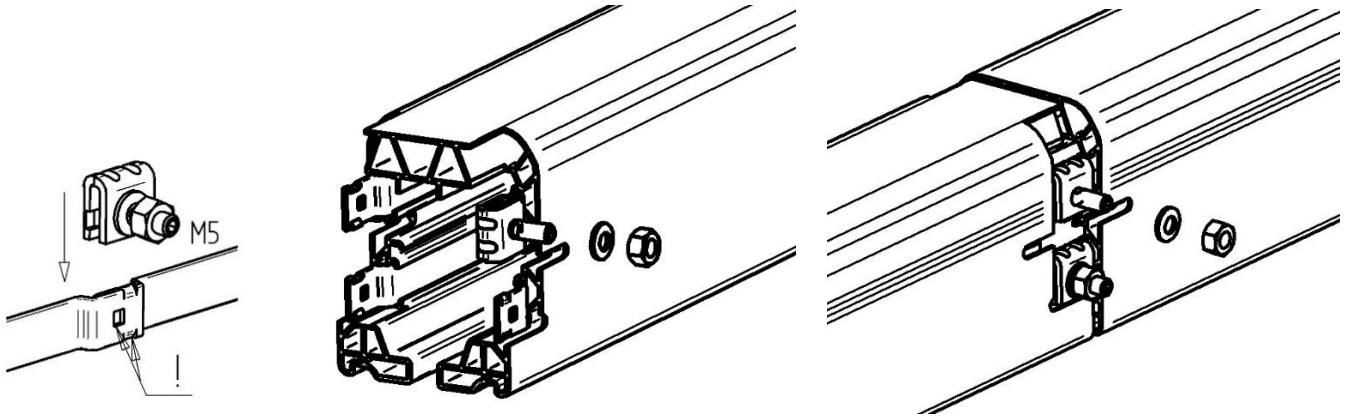

Mounting and dismounting required tools:



5-Covering flange

Accessory for electrical insulation of the junctions

Advantages

- Clipped-on assembling, no tools required
- Intuitive positioning

Description

The covering flange is used to protect the operator against direct contact with the connections. It also ensures the protection of the junctions against hard conditions of the environment.

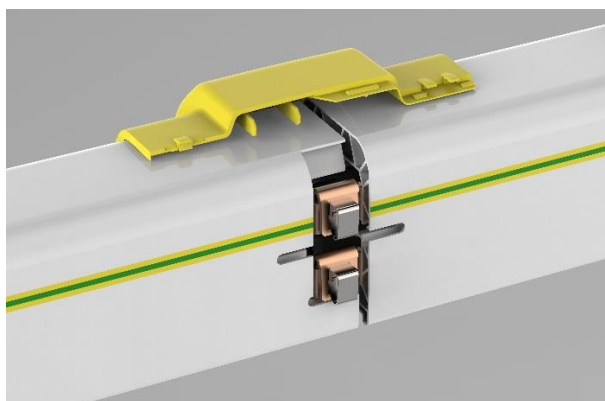

Product number and compatibilities

MI2000

Overall dimensions

L (mm) : 75

H (mm) : 84

Z (mm) : 125

Weight:

0,080kg

Mounting

Installation rules

Mount and dismount offline only.

Provide one element at each junction, outside feeding points.

Below an ambient temperature of -20°C , carefully assemble and disassemble this accessory.

Mounting rules

1. Connect the two lines elements
2. Close the covering flange on the connection

6 **Couvre joint**
Covering flange
Verbindungsabdeckung
Tapajunta

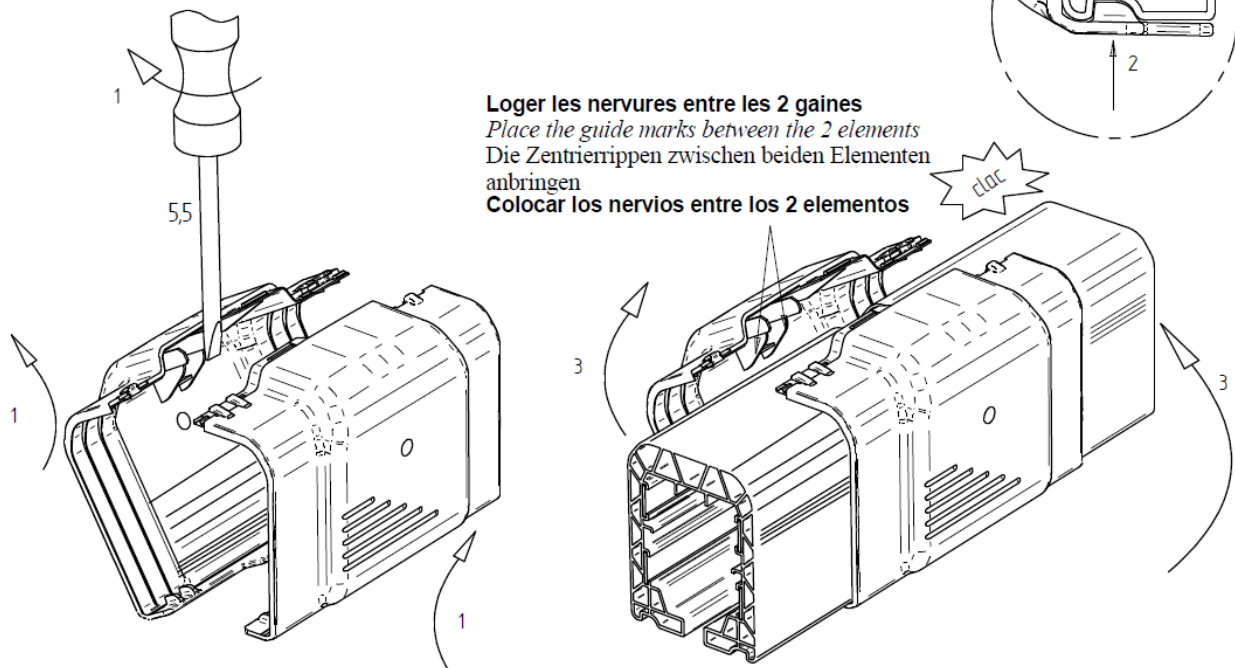

Mounting required tools



Dismounting required tools



6-End-cap

Provides the insulation of live elements at the ends of the line

Advantages

- Clip-on assembling, no tools needed
- Interchangeable shell with feed box shell

Description

The end-cap must be placed at each end of the line to ensure operator protection. Its use is required for CE conformance.

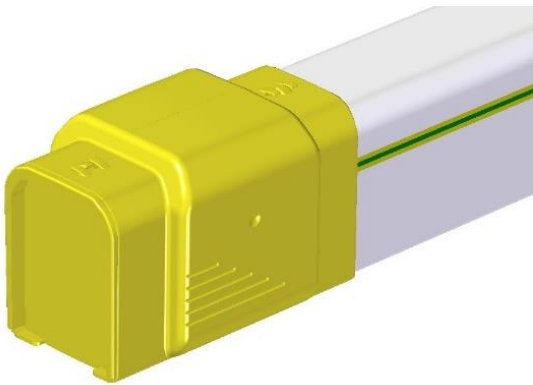

Product number and compatibilities

MI2400.

Technical data

Area with no access to the trolley: 30mm. Extra Length at end of line: 64mm

Overall dimensions

L (mm) : 75
H (mm) : 92
Z (mm) : 128

Material

Self-extinguishing thermoplastic

Weight:

0,140kg

Edition of 13/06/2019

Mounting

Installation rules

Mount and dismount offline only

To be positioned at the end of the line. Provide enough space at end of line to mount it (8cm mini) and so as not to impede line expansion (minimum of 2.5cm for 100metres)

Under -20°C mount and dismount this accessory carefully.

Mounting rules

1. Open the end-cap, 2 Insert the part with straight angles, 3. Tighten the screw, 4. Close the cap on the line making sure that the grooves are on one another.

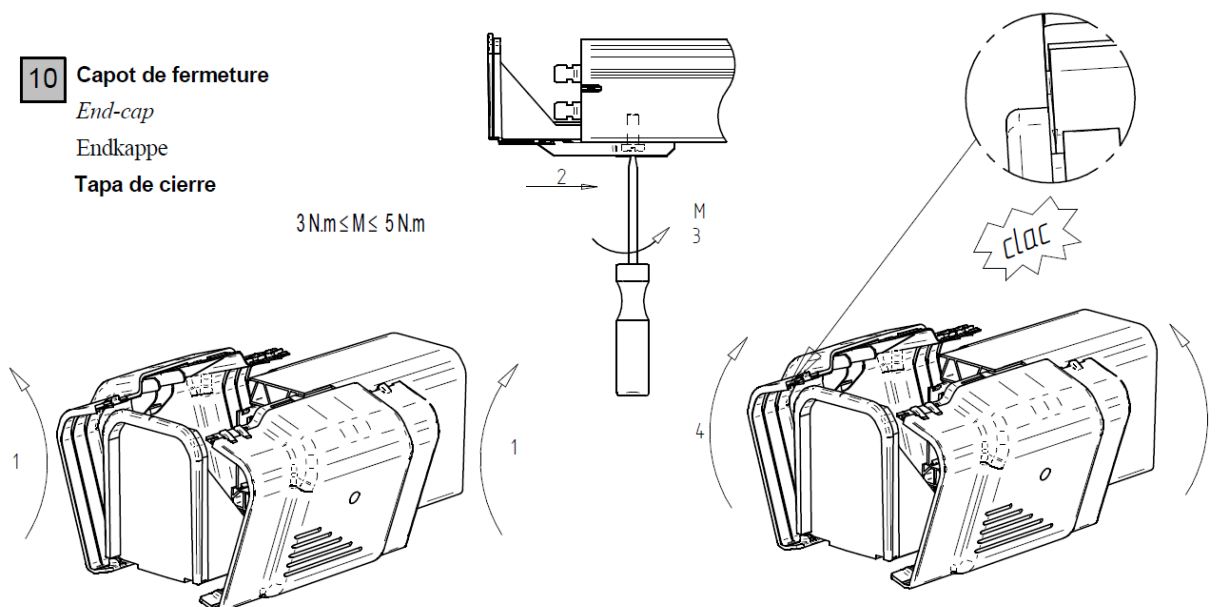

Mounting and dismounting required tools



7-Sliding hanger

Supports the line and allows expansion, self-aligning with the line on assembly.

Advantages

- Self-alignment system
- Easy assembling by screw and simple clip-on of the line

Description

Fully pre-assembled accessory, provides the interface between the mounting brackets and the Mobilis INNO line elements.

The sliding hanger is used to support the line and allows its expansion. The line is inserted by simple insertion upwards. The suspension is fixed to the bracket by nuts to provide precised adjustment of alignment in height. Its spring is used for clipping the line elements and to absorb any shocks that may be given on the side of the installation.

To immobilize the line, consult the "Fixed hangers".



Product number and compatibilities

MI1510

Technical Data

With screw M8. Height adjustment range: 33mm.

Material

Zinc coated steel

Weight

0,150kg

Edition of 13/06/2019

Overall dimensions

L (mm) : 57 H (mm) : 154 Z (mm) : 38

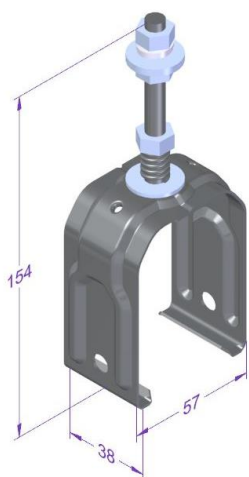

Mounting

Installation rules

Place the suspensions to receive the elements at a sufficient distance from the support to allow access to the connections and to place the accessories (cover, feeding box): recommended minimum space 100mm.

Mounting rules

Requires two wrenches No. 13 for assembling on the support. Position the sliding hanger 350mm from the end, then every 2m for 2 sliding hangers per line and every 1.33m for 3 sliding hangers per line. Simply clip-on the line elements between the sides of the sliding hanger.

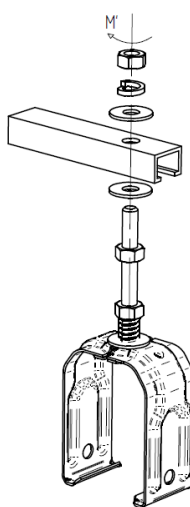

L (m)	$L < 1,5$	$1,5 \leq L \leq 4$
	1	2
X	/	L/2

Mounting und dismantling required tools



8-Fixed hanger

Fixes the position of the line

Advantages

- Fitted with red washer of visual location
- Self-alignment system

Description

The fixed hanger is built on the basis of the sliding hanger. It is entirely pre-mounted and equipped with 2 compression screws immobilizing the profile of the line elements.



Product number and compatibilities

MI1500

Technical data

Delivered with 2 built-in anchoring screws and red locating washers

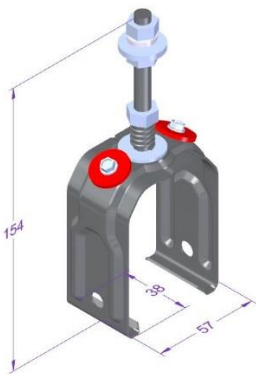

M8 screw
Height adjustment range: 33mm.

Edition of 13/06/2019

Weight:

0,160kg

Material

Zinc coated steel, red plastic washers

Mounting

Installation rules

The fixed hangers are always placed on a same element of the line. 2 items on the straight elements or the transfer elements. Place the fixed hangers midway in the line.

Mounting rules

Clip-on the elements of the line, place them longitudinally: tighten fully the 2 compression screws.

4 Point d'ancrage
End-cap
Endkappe
Punto fijo

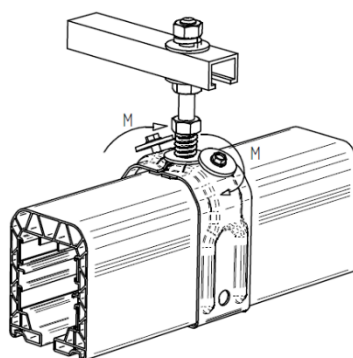
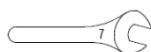

Mounting and dismounting required tools

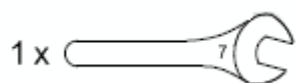
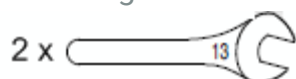

9-End-line feed box

Interface accessory for the electrical connection at the end of the line.

Advantages

Horizontal cable outlet, M25, M32 cable glands

IP 23: Index of protection against access to dangerous parts and rain.





Description

For electrical connection of the installation end of line with copper and aluminum flexible cable. Feeds in line are also available. Direct connection of cables with 5mm diameter terminals to feeding connections.

For use with aluminum cables, provide bi-metallic cable terminals aluminum-copper and cables of minimum section of 16mm² in accordance with Standard NF EN 60204-32 §13.2. Exists in 2 executions; one with cable gland on the bracket (AV) and one with cable gland on the shell (AR). This last version can be repositioned in the course of the line, in the place of a covering flange. Delivered with 4 feeding connections and pole marking label. Terminals not provided.



Product number and compatibilities

Cable-gland	M25 AV	M25 AR	M32 AV	M32 AR
Feed box				
References	MI1200	MI1201	MI1230	MI1231
Cable diameter	13-18mm	13-18mm	15-25mm	15-25mm
Dimension A	154	148	159	148
Dimension B	90	64	95	64
Weight (kg)	0,320	0,320	0,330	0,330

Technical data

Area on line with no access to the trolley: 30mm.

Material

Self-extinguishing thermoplastic

Overall dimensions

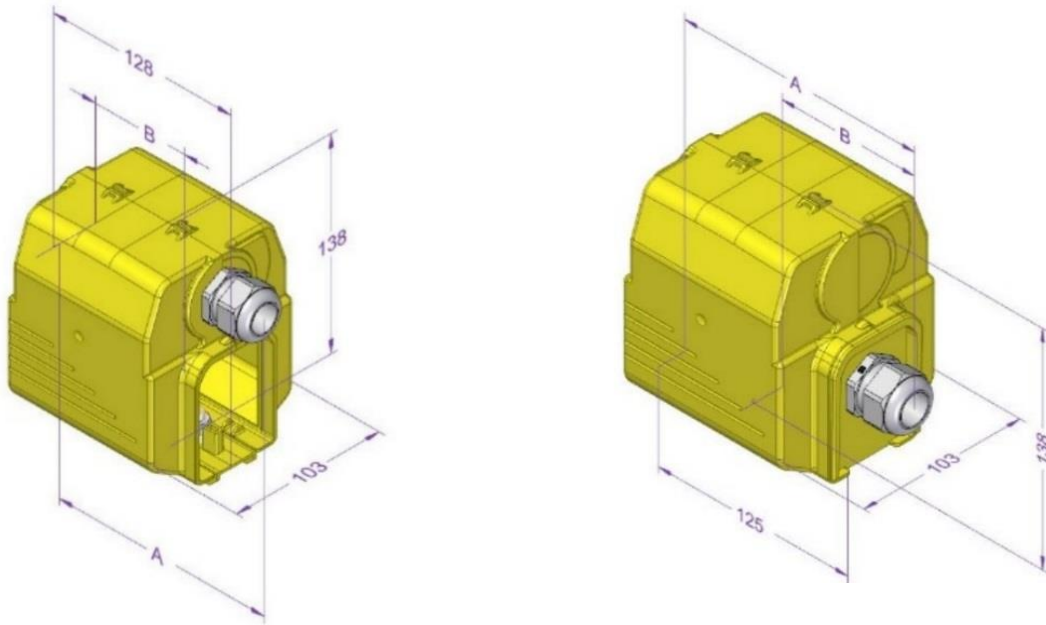

Mounting

Installation rules

For choosing an end-line feeding point, consider the overall length of the line for calculating the voltage drop. Provide a flexible wiring so as not to impede the expansion of the line. Fitted in place of an end-cap.

Mounting rules

The cable should not impede the free expansion of the line: provide adequate free loop of flexible cable. Provide cable terminals $\varnothing 5\text{mm}$.

9 Alimentation en bout
End line feed box
 Kopfeinspeisung
 Alimentación extrema

MI1200-MI1201-MI1230-MI1231

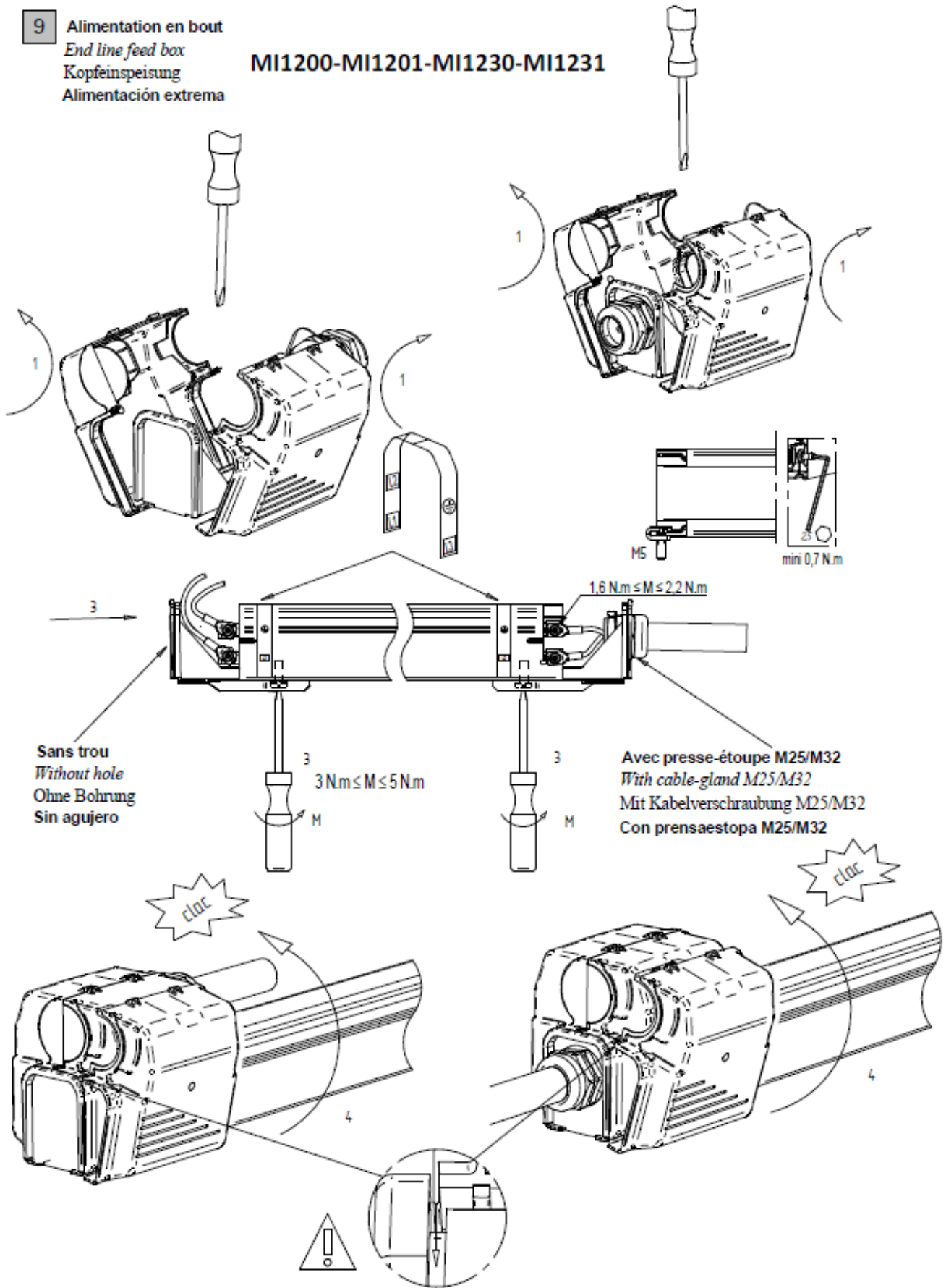

Mounting und dismounting required tools



10-M25-M32 in-line feed box

Interface accessory for the electrical connection of the line on a connection in-line.

Advantages

- In-line feed reduces the voltage drop
- Repositionable at the end of the line

Description

To be inserted in replacement of a covering flange for the electrical connection of the installation in-line with a flexible cable of copper or aluminum. End feed boxes are also available.

Direct connection of cables with 5mm diameter terminals to feeding connections.

For use with aluminum cables, provide bi-metallic cable terminals and cables of minimum section 16mm² in accordance with Standard NF EN 60204-32 §13.2.

Delivered with 4 feeding connections MI1010 and pole marking label. Terminals not provided.



Product number and compatibilities

Feed box	Cable-gland	
	M25	M32
References	MI1300	MI1330
Cable diameter	13-18mm	15-25mm
Dimension A	145	145

Technical data

Material

Self-extinguishing thermoplastic

Overall Dimensions

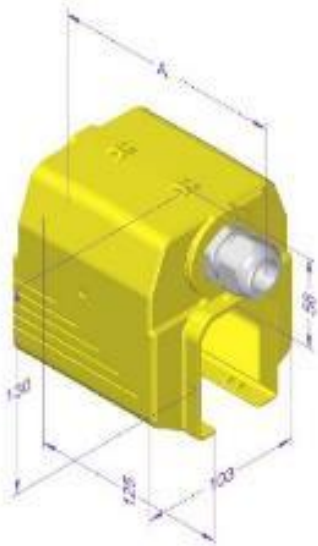

Mounting

Installation rules

Providing one or more feeding points in line rather than end-of-line reduces the voltage drop ($\Delta U = L_t \cdot \sqrt{3} \cdot Z \cdot I$) and allows to choose a lower intensity because the length 'Lt' taken into account in the calculation varies according to the number of feed boxes. Providing a feeding point midway in the line halves the voltage drop, as the 'Lt' section taken into account equals half of the line's length. For more than one feeding point in line, please review the following graph for the position of the points and related voltage drop.

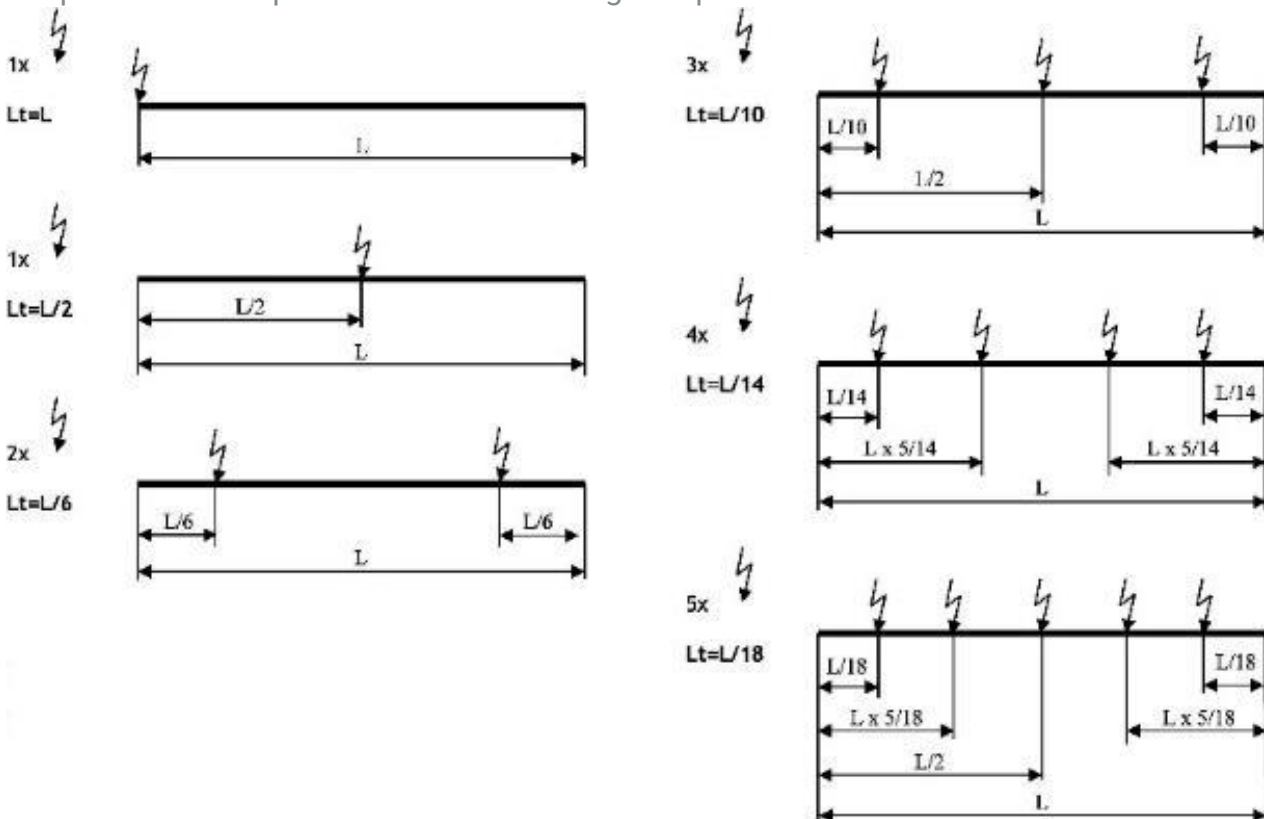

Mounting rules

The cable should not impede the free expansion of the line: provide adequate free loop of flexible cable. Provide cable eye stiffeners of connection $\varnothing 5\text{mm}$, screws and bolts not included. Use the 4 provided feeding connections for connecting the cables.

- 8** Alimentation en cours
In-line feed box
 Streckeneinspeisung
 Alimentación en el recorrido de la línea

MI1300-MI1330

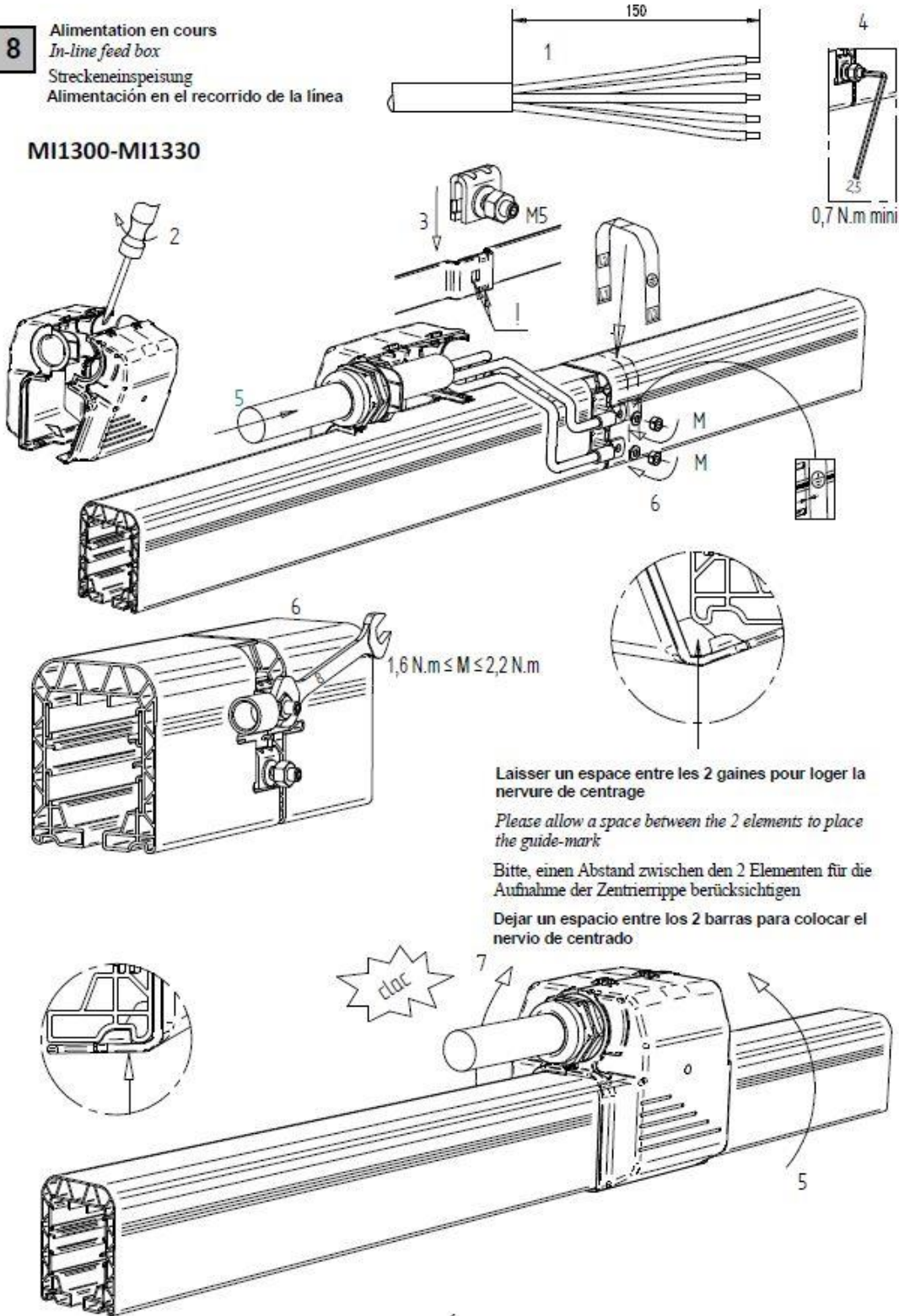

Mounting and dismounting required tools



11-M40 in-line feed box

Interface accessory for the electrical connection on a junction in-line.

Advantages

In-line feed reduces the voltage drop
For connecting high sections cables

Description

To be inserted in replacement of a covering flange for the electrical connection of the installation in-line with a flexible cable of copper or aluminum. In case of use of rigid cable, please contact us.

For use with aluminum cables, provide cables of minimum section 16mm² in accordance with Standard NF EN 60204-32 §13.2. Feeding by direct connection of cables supplied and pre-equipped with terminals diameter 5mm on the conductors of the line element thanks to feeding connections.

Delivered with 4 feeding connections MI1010 and pole marking label.

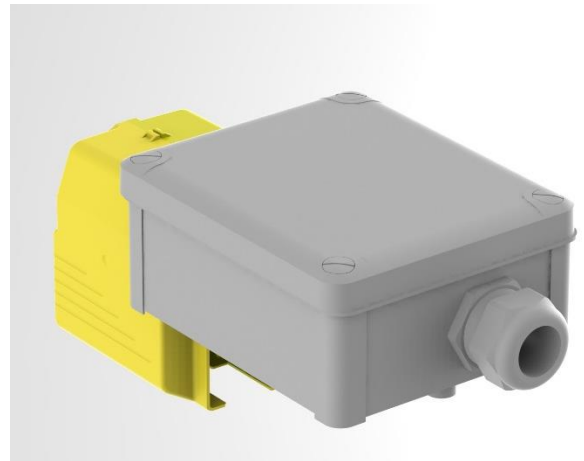
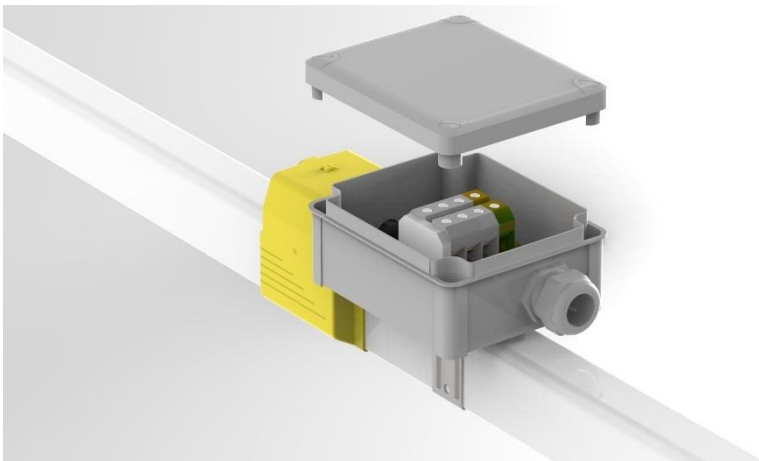

Product number and compatibilities

Cable-gland	M40
Feed box	
Référence	MI1332
cable diameter	22-32mm

Technical data

Capacity of the terminal block: 35mm²

Material

Self-extinguishing thermoplastic, Zinc coated steel

Overall dimensions

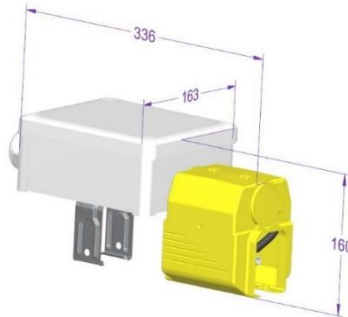

Mounting

Installation rules

Providing one or more feeding points in line rather than end-of-line reduces the voltage drop ($\Delta U = L_t \cdot \sqrt{3} \cdot Z \cdot I$) and allows to choose a lower intensity because the length 'Lt' taken into account in the calculation varies according to the number of feed boxes. Providing a feeding point midway in the line halves the voltage drop, as the 'Lt' length taken into account equals half of the line's length. For more than one feeding point in line, please review the following graph for the position of the points and related voltage drops.

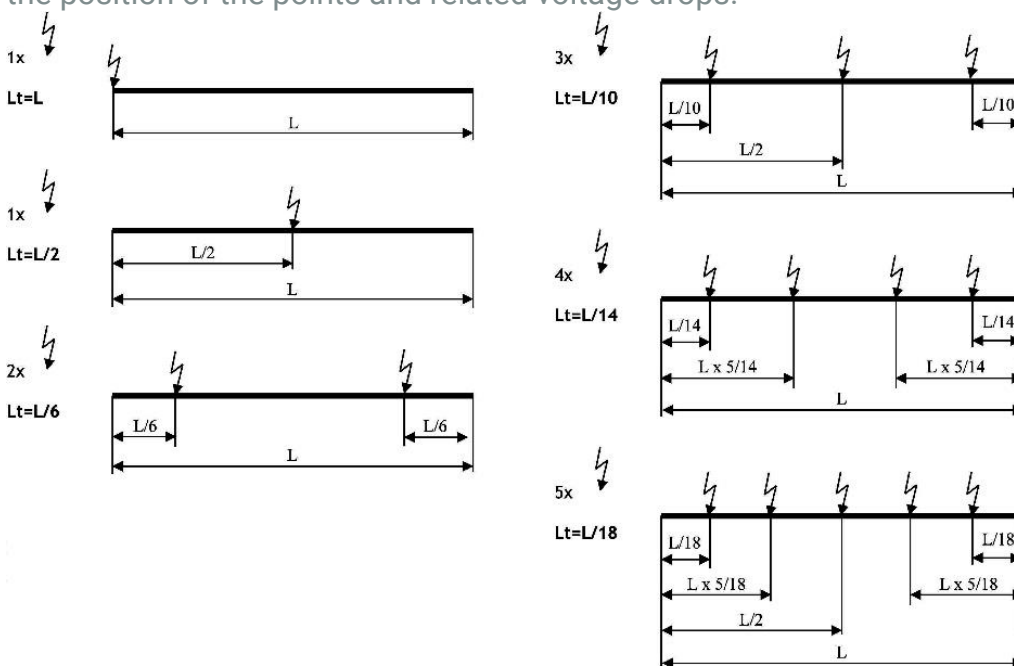

Mounting rules

The cable should not impede the free expansion of the line: provide adequate free loop of flexible cable.

If single wire aluminium cables are used (multistrand prohibited), use contact lubricant.

If rigid cables are used, ask for the specific application data sheet.

MI1332

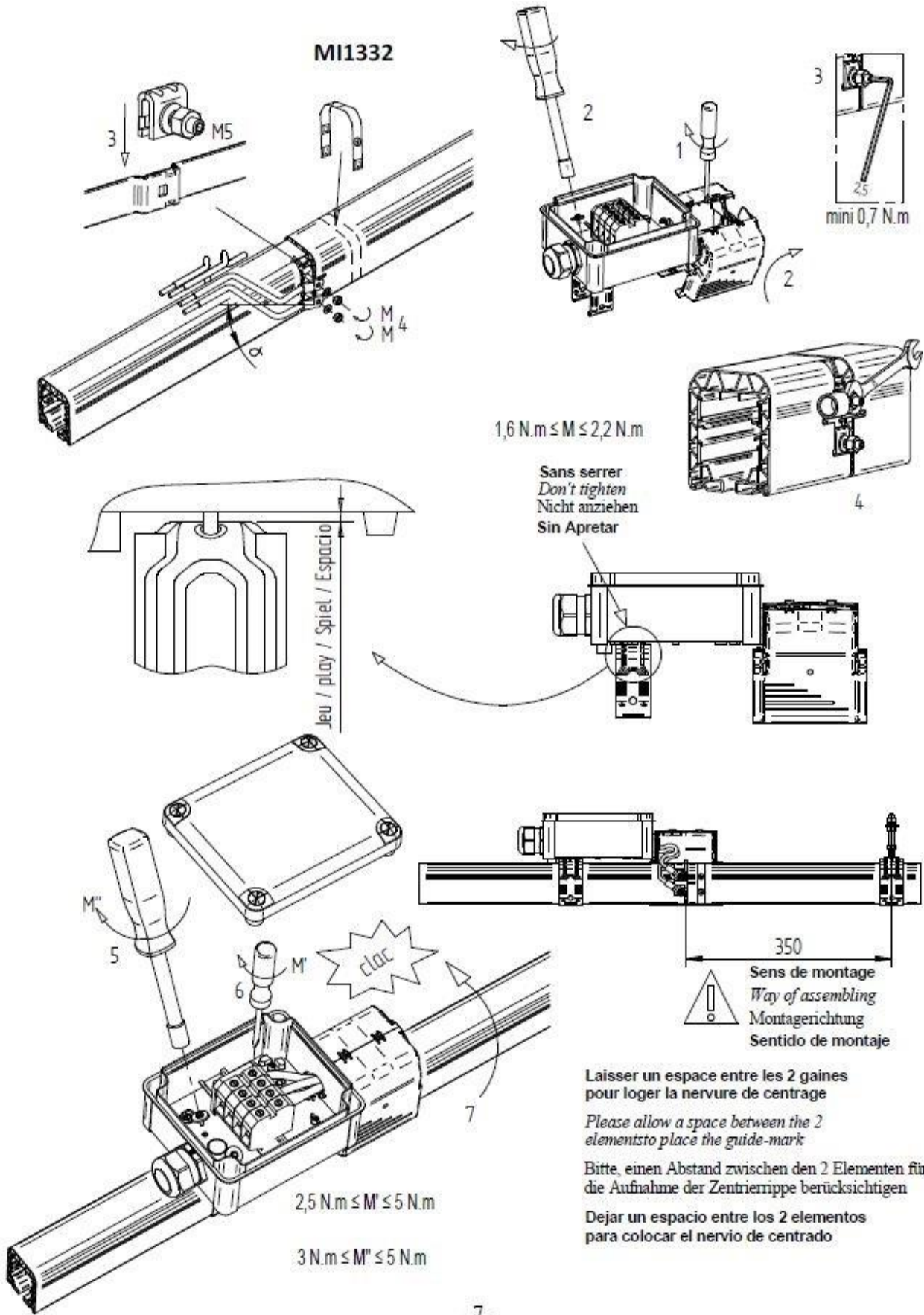

-7-

Mounting and dismounting required tools



12-Rigid trolleys

The collector trolley shunts the electrical current in the Mobilis INNO line to the mobile device requiring power.

Advantages

- Compact design under the line element
- Economical wearing part

Description

The rigid trolley is designed to shunt the electrical current in straight installations operating at speeds up to 60m/min. It is not intended to support a load.

It is inserted into the line by matching poles using a system of safety pins.

The mechanical link between the trolley and the mobile device is ensured by the carrier. The self-lubricating carbon brushes, mounted on springs, thereby guaranteeing a permanent contact with the conductor.

The trolley is available in 6 versions:

- two versions without cable, in single trolley version and double trolley version
- four pre-wired versions (HO7-RNF cable with green-yellow wire), in single trolley version and double trolley version. 4 x 4 mm² or 6 mm² cable.

The prewired trolley can be delivered with a cable length of 1m (standard), or more (on request).

The carbon brush (or brushes) are the parts of the Mobilis INNO trolley most subject to wear. They can be easily replaced without intervention on wiring. A simple screwdriver is all that is needed.

The single trolley can shunt up to 35 A when travelling, 70A for double trolley.



Product number and compatibilities

Single trolley compatible with single carrier.
Double trolley compatible with double carrier.

	4 Poles	
	Single rigid trolley	Double rigid trolley
Rated current	35A	70A
Weight (kg)	0,33	0,65
Terminal block	6mm ²	
Compatible cable	flexible cable from 2,5 mm ² to 6 mm ²	
With 1m câble 4mm ² HO7-RNF	MI2034-1M	MI4034-1M
With 1m câble 6mm ² HO7-RNF	MI2036-1M	MI4036-1M
Without cable	MI2030	MI4030

Technical data

Max speed 60m / min.

For copper cables Ø13 to 18.5 mm, section 2.5 mm² to 6 mm², flexibility class 5 minimum.

Contact quality: no contact micro-cutoffs > 1ms at 60m / min (<3ms as recommended by EN 60204-32)

Authorized conditions of use for stationary application		
Duration	current single trolley	current double trolley
40seconds	33A	66A
5 minutes	25A	50A
30 minutes	17A	34A
≥1 hour	14A	28A

Overall Dimensions

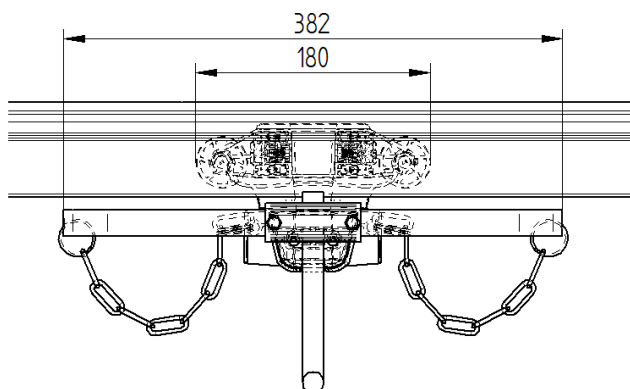

Mounting

Installation rules

Mount and dismount offline only.

The trolley must be inserted at the end of a line element.

The terminal block is accessible from the side of the color band of the line element.

Mounting rules

Provide adequate loop of cable so as not to impede the motion of the trolley

The drive of the trolley must be realized thanks to our carrier by traction on the chains, ideally in the axis of the line element for a maximum lifetime.

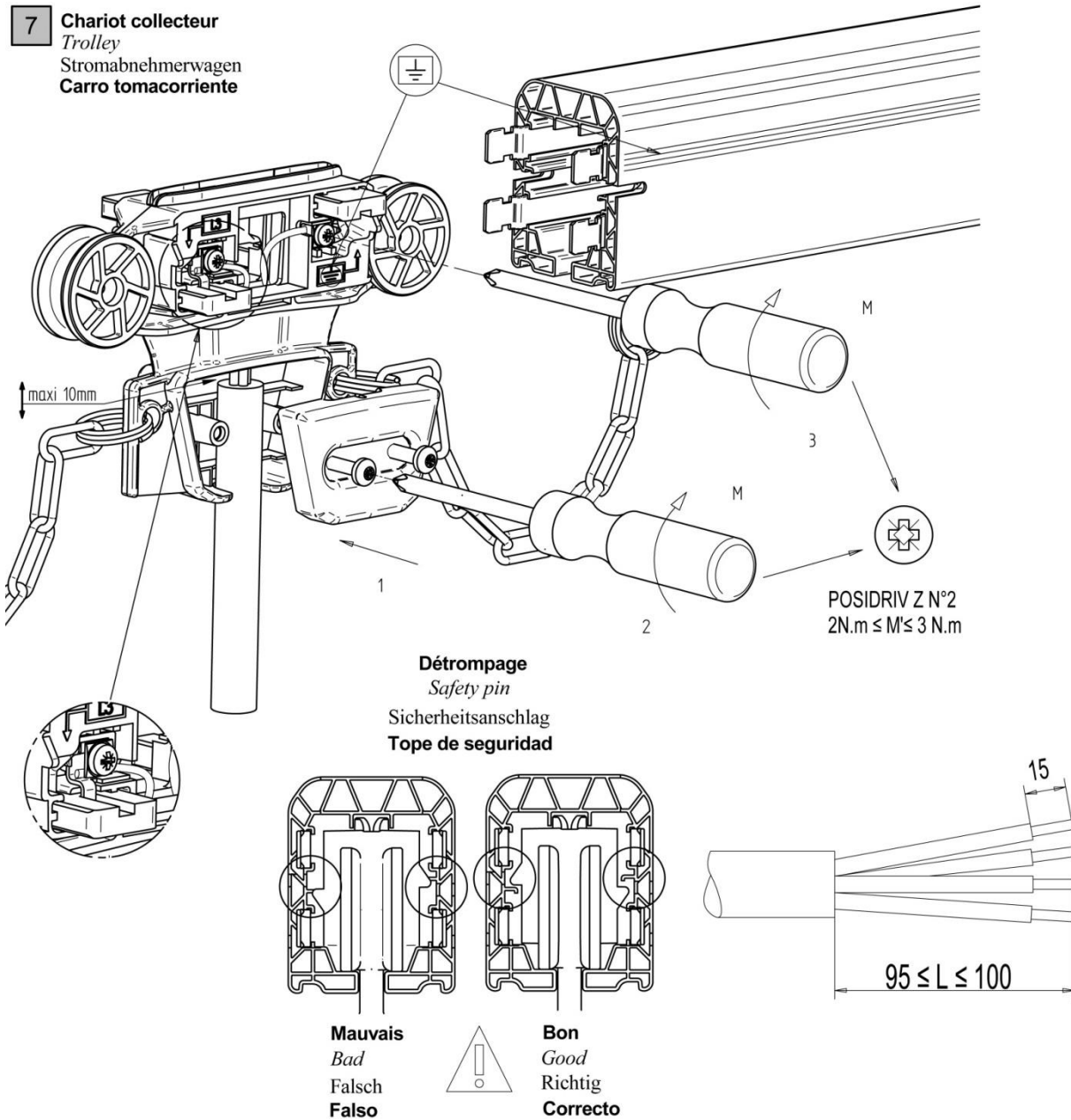

Mounting and dismounting required tools



Carrier

Element of mechanical link between the collector trolley and the mobile device requiring power

Advantages

Large vertical and lateral clearance
For driving squares 30 to 50mm

Description

The standard carriers ensure the mechanical link between the collector trolley which travels inside the Mobilis INNO line and the mobile device requiring current. They exist for 2 driving square sizes.

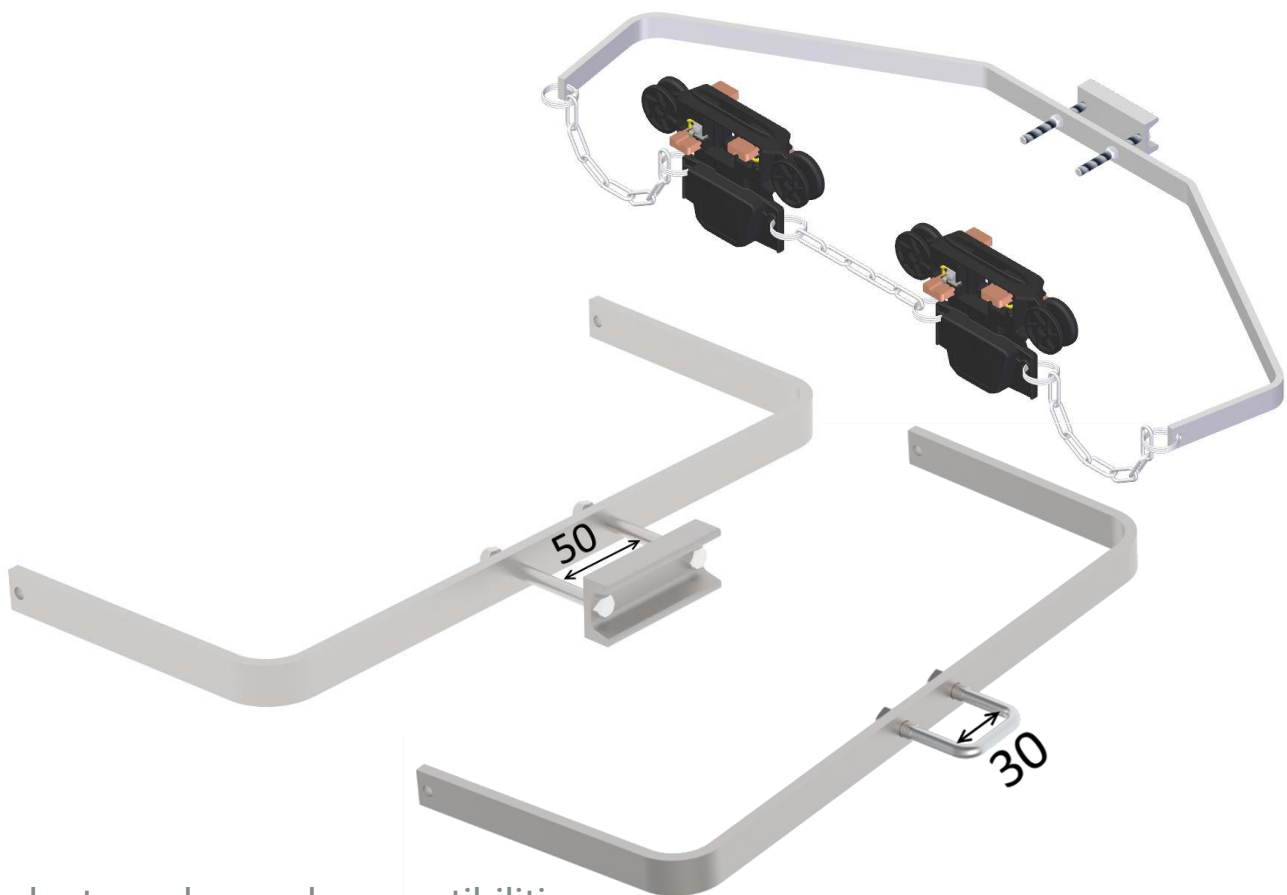

Product number and compatibilities

Carrier	Simple		Double	
	30	50	30	50
driving square	30	50	30	50
Reference	MI1623	MI1625	ME1615	ME1610
Compatibility with the trolley	30		60	
Length H	20mm		20mm	
Length L	370mm		702mm	
Length P	160mm		245mm	
Permissible vertical clearance	+0/-50		+0/-50	
Permissible horizontal clearance	±50		±50	
Weight	0,6kg		1,1kg	

Technical data

See references table

Overall dimensions

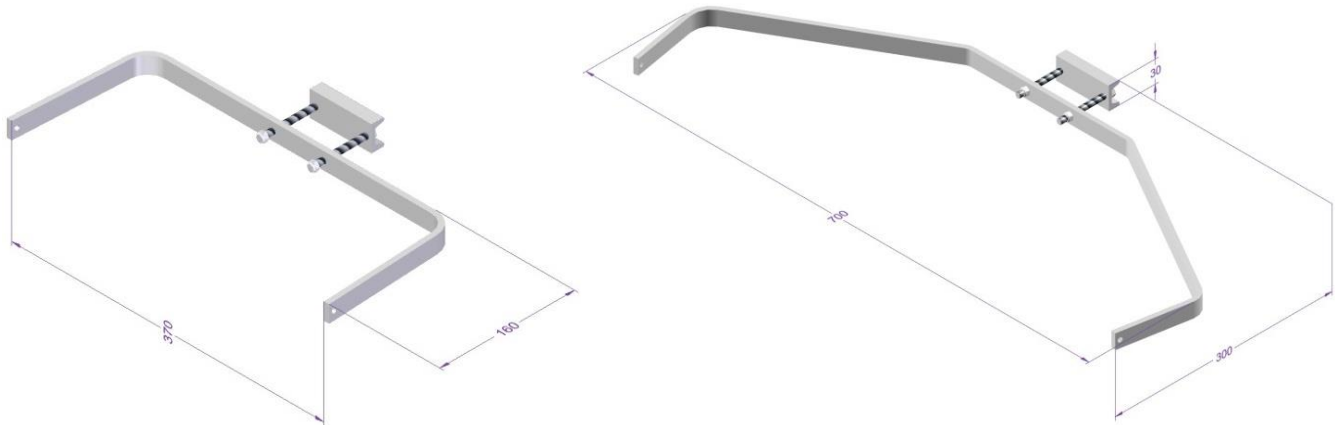

Material: Zinc coated steel

Mounting

Installation rules

Check that the space required for the carrier is available all along the line.

Mounting rules

Adjust in the vertical plane to have the chain of traction of the trolley horizontal or tended downwards (max. -30mm). In the horizontal plane, the chain of the trolley must be in the axis of the line +/- 30mm. A correct adjustment increases the life time of the trolley.

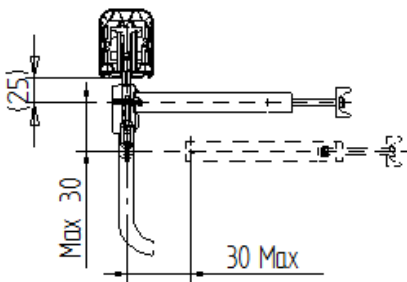

Mounting and dismounting required tools

For driving square sizes 30:

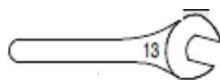

For driving square sizes 50:

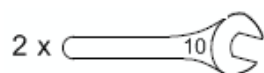

14-Carrier with box

Element of mechanical link and electrical connection between the collector trolley and the mobile device requiring power

Advantages

Box with intermediate terminal between the trolleys and the mobile device requiring power
For driving squares 30 to 50mm

Description

The carriers with box ensure the mechanical link between the collector trolley which travels inside the Mobilis INNO line and the mobile device requiring current. They also provide an intermediary connection point between the collector(s) carried and the supply cable of the mobile device.

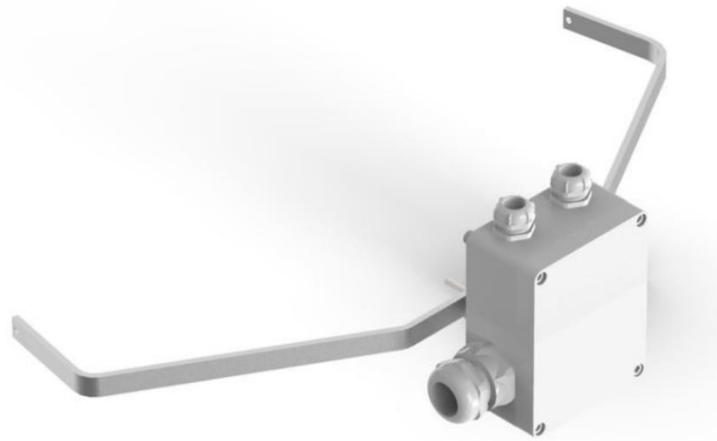

Product number and compatibilities

Carrier	Simple	Double
driving square	50	
Reference	ME1660	ME1640
Compatibility with the trolley	30 A	60 A
Maximum duty cycle factor to 40°C w.4G10	100%	80%
Maximum duty cycle factor to 55°C w.4G10	100%	55%
Output cable gland (to box)	1xM40	
Diameter of output permissible cables	Ø21-32mm	
Input cable gland (to trolley)	1xM25	2xM25
Diameter of output permissible cables	Ø13-19mm	
Cable connection	to 4x16mm ²	to 4x25mm ²
Length H	20mm	20mm
Length L	370mm	702mm
Length P	160mm	245mm
Permissible vertical clearance	+0 / -30mm	
Permissible horizontal clearance	± 30mm	
Weight	1,4kg	1,9kg

Technical data

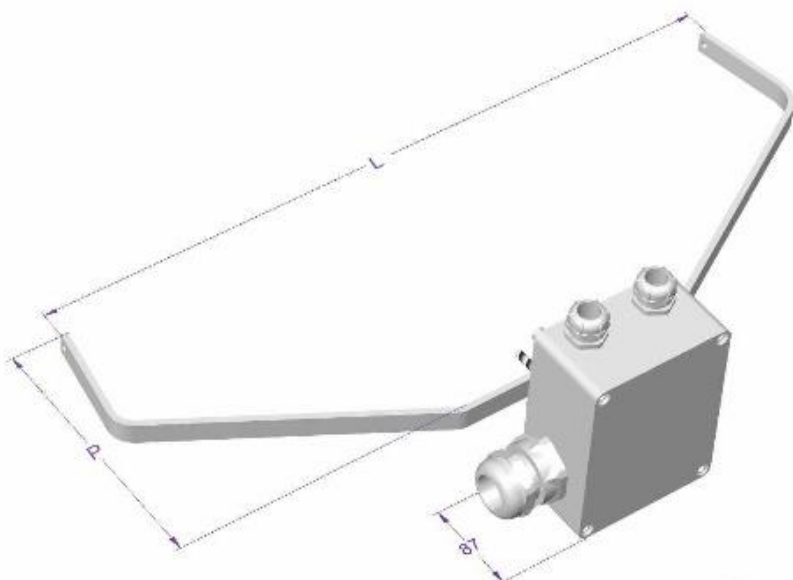

Material: Zinc coated steel and ABS

Mounting

Installation rules

Check that the space required for the carrier is available all along the line.

Mounting rules

Adjust in the vertical plane to have the chain's traction of the trolley horizontal or tended downwards (max. -30mm). In the horizontal plane, the chain of the trolley must be in the axis of the line +/- 30mm. Correct adjustment increases the life time of the trolley collector.

Mounting and dismounting required tools:

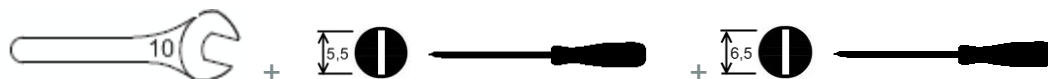

15-Switching finger

Stop for electromechanical end position

Advantages

- Position can be changed easily
- Easy fit on the Mobilis INNO line

Description

Located on one element of the line, it allows the overhead travelling crane provided with a cross-type sensor limit switch to detect a position or the end of line with no other elements required to be fitted to the structure.

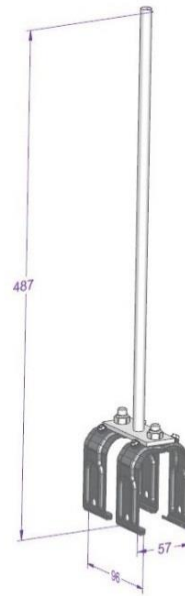

Product number and compatibilities

MI1550

Technical data

Mounting

Installation rules

To be positioned normally at each end of the line. Provide suitable space to allow the travelling crane to stop at full speed.

Mounting and dismounting required tools

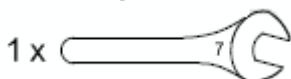

16-Bracket

Ensures the mechanical link between the structure of the frame and the sliding hangers, fixes the position of the line in relation with the running rail.

Advantages

- Available in fast assembling version
- Various lengths available



Description

The fixing bracket allows to maintain the distance between the line and the travel path. This distance must be as parallel as possible. The Bracket must be chosen according to the wing-thickness of the beam on which it is attached, according to the center distance between the beam and Mobilis and according to the weight to support. The standard bracket requires access from both sides of the beam for tightening the clamps. The position of the hole must be adjusted in relation to the running rail. 2 section profiles are available and will be selected based on the load to be supported (weight of element, number of suspensions by element, trolley, parasitic load - ice). The fast assembling clamped bracket requires access from only one side, in abutment to the screws. The hole is automatically positioned in relation to the beam edge.

Restrictions of use for the fast assembling bracket: - only for interior use

Product number and compatibilities

The following references include several types of supports: fast assembling or not, and for beams up to 20mm or 32mm of thickness.

Reference	Type of mounting	Overall length	Allowable beam thickness	Section A x B	Weight
ME1700	Standard	380	6 to 20mm	14 x 20 mm	0,5 kg
ME1750	Standard	500	6 to 20mm	14 x 20 mm	0,6 kg
ME1760	Standard	600	6 to 20mm	28 x 30 mm	1,0 kg
ME1765	Standard	600	15 to 32mm	28 x 30 mm	1,0 kg
ME1780	Standard	850	6 to 20mm	28 x 30 mm	1,2 kg
ME1785	Standard	850	15 to 32mm	28 x 30 mm	1,2 kg
ME1799	Fast	240	7 to 40mm	-	0,4kg

Technical data

Brackets in 1000mm length are available on request. The bending resistance of these brackets have to be considered on a case-by-case basis according to the cantilever distance and the overhung load.

Rated temperature: -30°C to +75°C

Material : Zinc coated steel

Mounting

Installation rules

Number and position according to the rules for placing the sliding hangers.

Mounting rules

Align the assembling holes of the sliding hangers in parallel to the travel path

Fast bracket ME1799 :

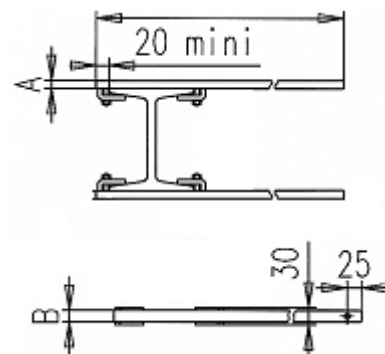
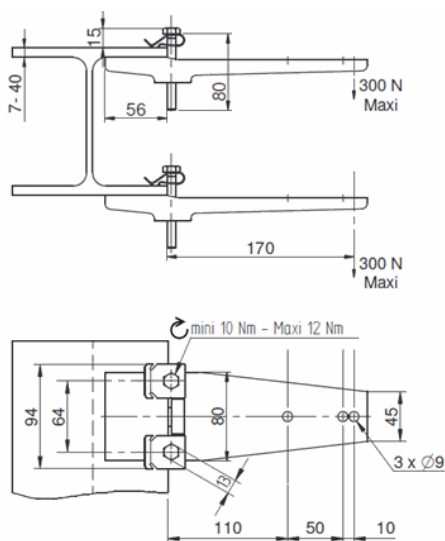

Mounting required tools

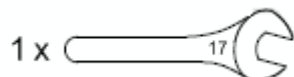
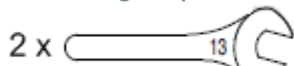

Dismounting required tools

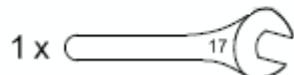
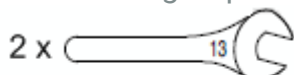

17-Cleaning trolley

The cleaning trolley is designed to clean the conductors

Advantages

- Restores contact quality
- Removes pollution on the conductors

Description

Maintenance accessory used for the renovation of the conductors operating in a dusty environment, very humid environment, slight surface roughness of the conductors, projection of particles towards the line... The frequency of use of the cleaning trolley depends on the application. Caution: the cleaning trolley brushes wear more rapidly than the collector brushes. Do not couple permanently.

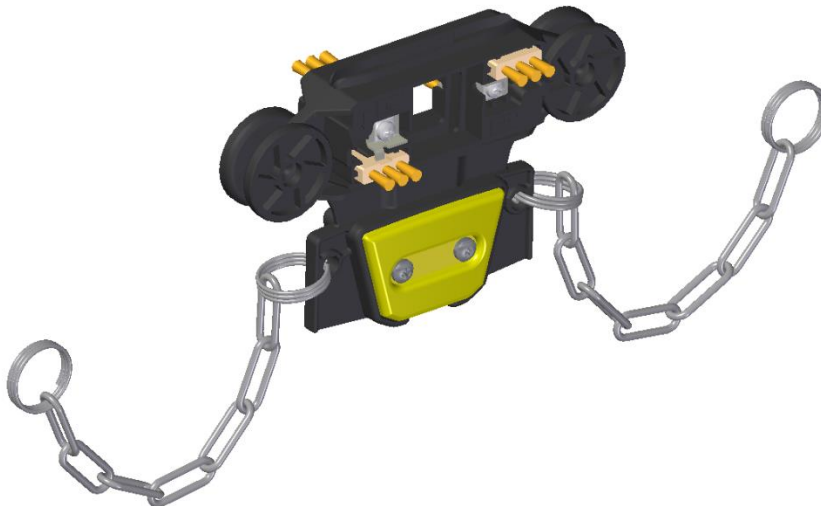

Product number and compatibilities

MI4514

Technical Data

Designed to be used in the under-voltage rail.
Replaceable brass scrubbing brushes - brush Ref. ME0628.
Cannot shunt current.
Driven by simple carrier.
Max. travel speed 60m/min.

Overall dimensions

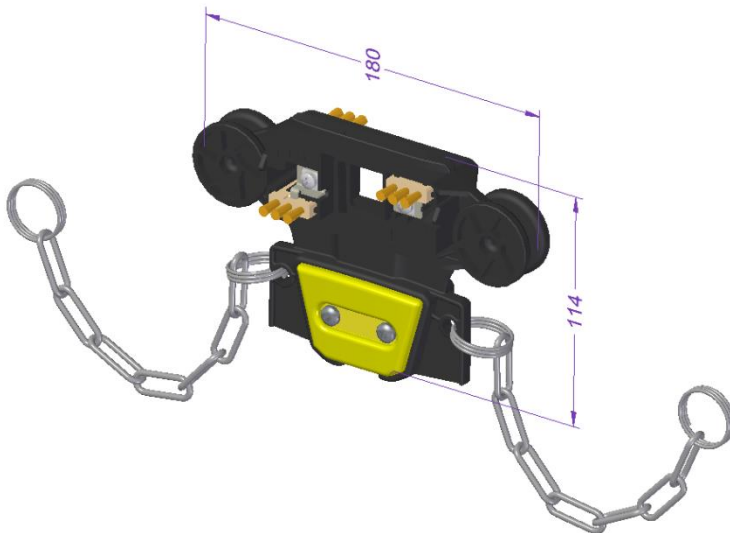

Mounting

Installation rules

To be inserted into the line after cut-off from the mains. The cleaning trolley is not intended to be coupled with the collector trolleys and must normally be operated separately to prevent premature wearing of the scrubbing brushes. Runs back and forth several times until the surface of the conductors are restored.

Mounting rules

Fit into the line in either direction of assembling. Move by hand, using a rope, or coupled with the mobile device via a single carrier ME1600.

Mounting and dismounting required tools

For the replacement of brushes only:



18-Replacement parts

Set of 4 collector brushes

Replacement carbon brushes for collector trolley

Description

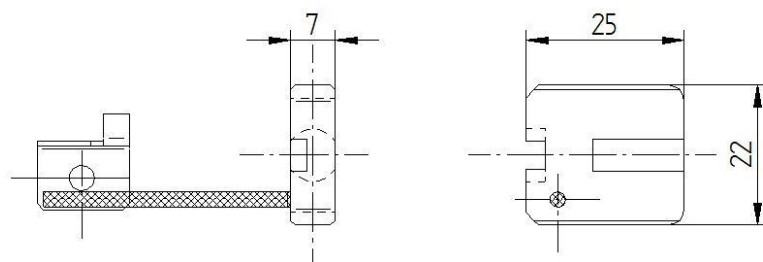

Product number and compatibilities

MI9001

For all collector trolley models

Cleaning brush

Replacement cleaning brush for cleaning trolley

Description

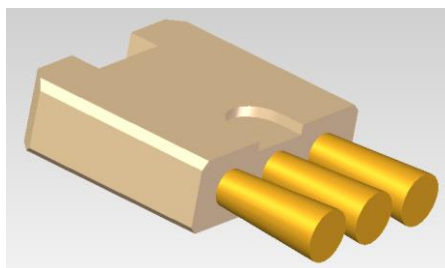

Product number and compatibilities

ME0628

Only for Inno cleaning trolley

GUARANTEE

Our equipment is guaranteed one year against any material or manufacturing defect recognized by ourselves. As we are not responsible for its installation and operation, our guarantee covers only replacement or repair (at our own choosing) of the part recognized to be defective.

We do not accept responsibility for any defects arising from faulty supervision or maintenance. We also disclaim liability for any production stoppages that may result. Any arbitration shall be held in Strasbourg, even when several defendants are involved.